

# HelioJET™ Central Cleaning System

# Model C-60



*Installation*

*Operation*

*Maintenance*

# Table of Contents

|                                     |       |
|-------------------------------------|-------|
| <b>Important Safety Precautions</b> | 3     |
| How it Works                        | 4-5   |
| Installation                        | 6-10  |
| Start-up                            | 11-13 |
| Trouble Shooting                    |       |
| - Steam Condensate Light            | 14    |
| - Other Trouble Shooting Tips       | 15    |
| Preventative Maintenance            | 16-19 |
| Major Components and Spare Parts    | 20-22 |
| Limited Warranty                    | 23    |

# Safety !



# Precautions

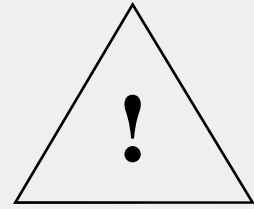

## **SAFETY PRECAUTIONS:**

Please be sure the following instructions are understood thoroughly BEFORE operating the HelioPAC. Consult our representative in your area or call the factory to resolve the items you do not understand.

This equipment can be used to generate:

1. A high pressure fluid that can penetrate the skin and cause severe internal injury!
2. A hot fluid which can severely burn the body.
3. A chemical solution ranging from mild to highly dangerous; protective equipment must be worn by the operator.

### **Therefore:**

1. **NEVER** exceed inlet pressure of 160 psig for either steam or water supply.
2. **NEVER** operate the system with a defective hose.
3. **ALWAYS** allow hose a minimum 9 inch bend radius.
4. **ALWAYS** check hose for kinks or abrasions that may develop into a rupture.
5. **ALWAYS** use hardware (valves, fittings, quick disconnects, etc.) which are rated for the maximum discharge pressure at which you could be operating.

### **REMEMBER:**

The HelioPAC is a powerful fluid pressure amplifier and condenser which can multiply the inlet pressure several times! For example, with 150 psig of inlet water and 150 psig inlet steam, the discharge pressure could reach 600 psig at 212°F and be laden with dangerous chemicals. The HelioPAC deserves respect!

Install in accordance with all applicable codes. Start-up/overflow shall be rigid, threaded pipe, firmly anchored directly to a drain and away from personnel. Adequately support all equipment and plumbing.

**OBSERVE ALL ADDITIONAL SAFETY PRECAUTIONS FOUND IN THIS MANUAL.**

# The Patented HelioPAC™

# How it works

Figure 1

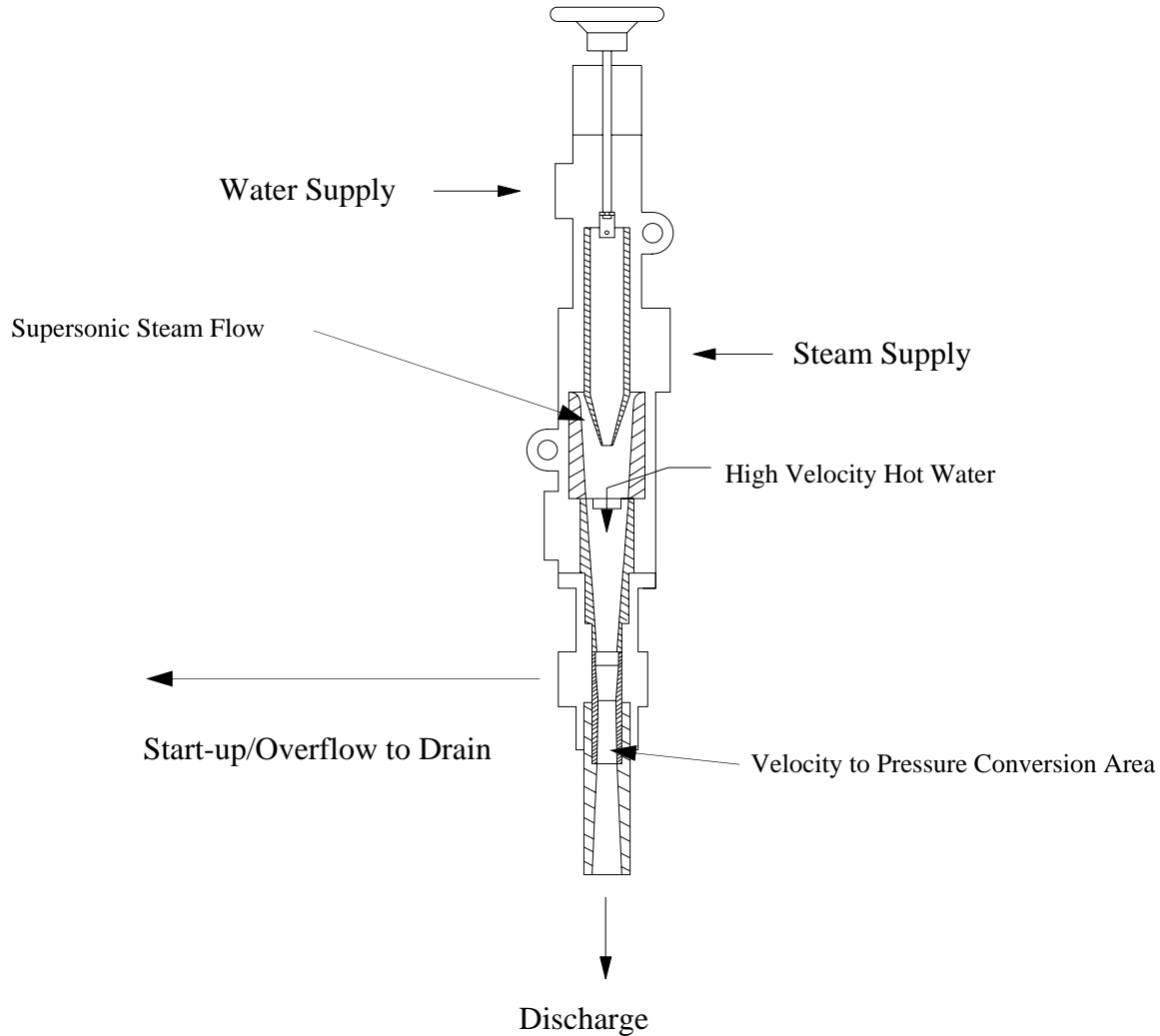

## The Patented HelioPAC

An entering stream of cold water encounters a supersonic stream of steam molecules within the device.

As the steam molecules condense into the water stream, momentum and heat transfer takes place. This transfer causes a significant increase in the temperature and velocity of the incoming water.

The HelioPAC converts this velocity to pressure, increasing the pressure of the incoming water up to 10 times.

# The Central Cleaning System

# How it works

Figure 2

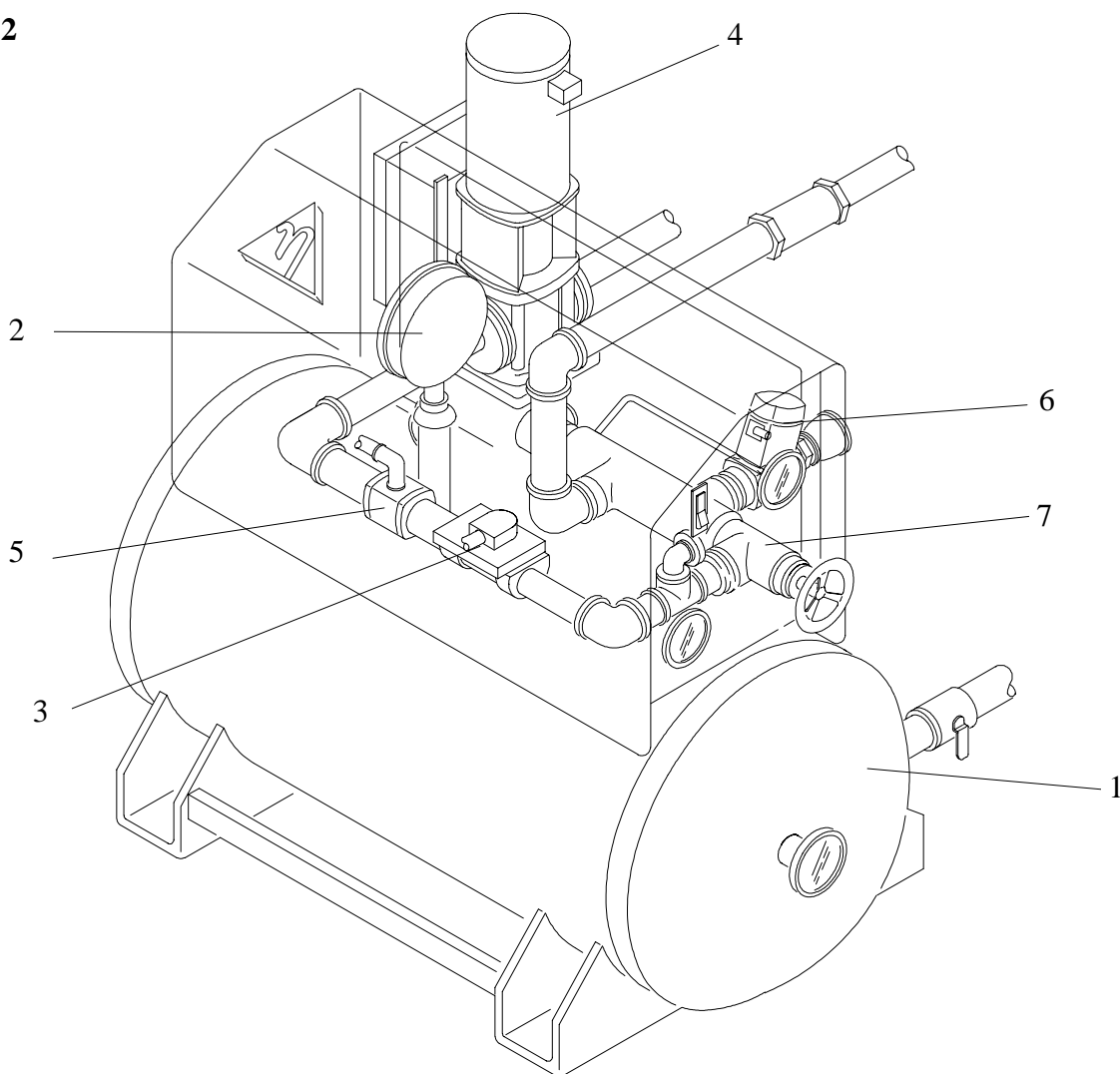

## The Central Cleaning System

Pressurized water is piped from the pressure reserve tank (1) to desired cleaning locations within the plant. As this water is used, pressure within the reserve tank drops. An electrical pressure switch (2) senses this drop and energizes the automatic water valve (3) and the stabilizer pump (4) which sends cold water through the water inlet line to supply the Heliopac (7). The flowing water closes the flow switch circuit (5) which energizes the air actuated steam valve (6) allowing steam to flow to the Heliopac, where it encounters the incoming water. The Heliopac starts and fills the reserve tank to the desired pressure, as set by the pressure switch. When the pre-set pressure is reached, the pressure switch opens and the system is in the stand-by mode, waiting to be used.

Follow these instructions and refer to pages and figure illustrations as specified.

Your HelioJET Central Cleaning System will require the following utilities and connections for proper operation:

- Cold water supply
- Steam supply
- Compressed air
- Floor drain
- Electricity
- High pressure discharge piping and spray equipment

### **Location**

It is recommended that you place your C-60 system away from production and other high traffic areas. A boiler or utility room is ideal. Placing the system in the proper location will avoid problems that can arise from tampering, water damage, etc.

### **Water Supply**

Use 2" cold water supply less than 80°F. Water supply pressure must be stable. The supply line should be dedicated exclusively to the HelioJET and piped directly from a larger main.

Install a manual shut off valve (sold separately) and be sure it is accessible from the HelioJET location. Always use a full port or oversized valve in order to avoid a pressure drop.

If your plant has a water hardness problem, be sure that the HelioJET is supplied with soft water. This will prevent fouling in the system.

### **Note:**

To optimize performance, always avoid pressure drops in supply lines. Locate the HelioJET as close as possible to the water and steam source, and never undersize piping. If the HelioJET must be located a considerable distance from supply mains, increase pipe diameters feeding the unit. Avoid the use of restrictive devices in piping, such as regulators, etc.

Before actually connecting supply lines, thoroughly flush them to remove any debris that may plug orifices within the HelioJET System.

### **Steam Supply**

The HelioJET C-60 requires a 2" dedicated steam supply line.

Install a full port or oversized manual shut-off valve, and be sure it is accessible from the C-60 location.

Standard HelioJET systems are designed to operate on steam supply pressures of 75-135 psi. If your steam supply pressure is outside this range, contact the HelioJET Technical Service Department for assistance. HelioJET systems can often be modified in the field to accommodate other supply conditions.

The C-60 will consume 40-65 lbs. of steam per minute depending on internal orifice configurations. This equates to a boiler requirement of 80-125 horse power. Please be sure you have enough boiler capacity to operate the system.

# HelioJET™ C-60

## Schematic

1. Water Supply: 2" NPT
2. Steam supply: 2" NPT
3. Start-up Overflow Drain: 1-1/4"
4. Steam Trap: 1/2" NPT
5. Start-up Vacuum Gauge:
6. HelioPAC: Hand Wheel Adjustment.
7. Discharge: 2" NPT (Spray Guns, etc.)
8. Thermometer.
9. Power Switch.
10. Discharge Pressure Gauge.
11. Pressure Reserve Tank: (200 Gallon A.S.M.E. rated 600 psi).
12. Pressure Switch: High– Low setting
13. Electrical Enclosure:
14. Water Supply Booster Pump.

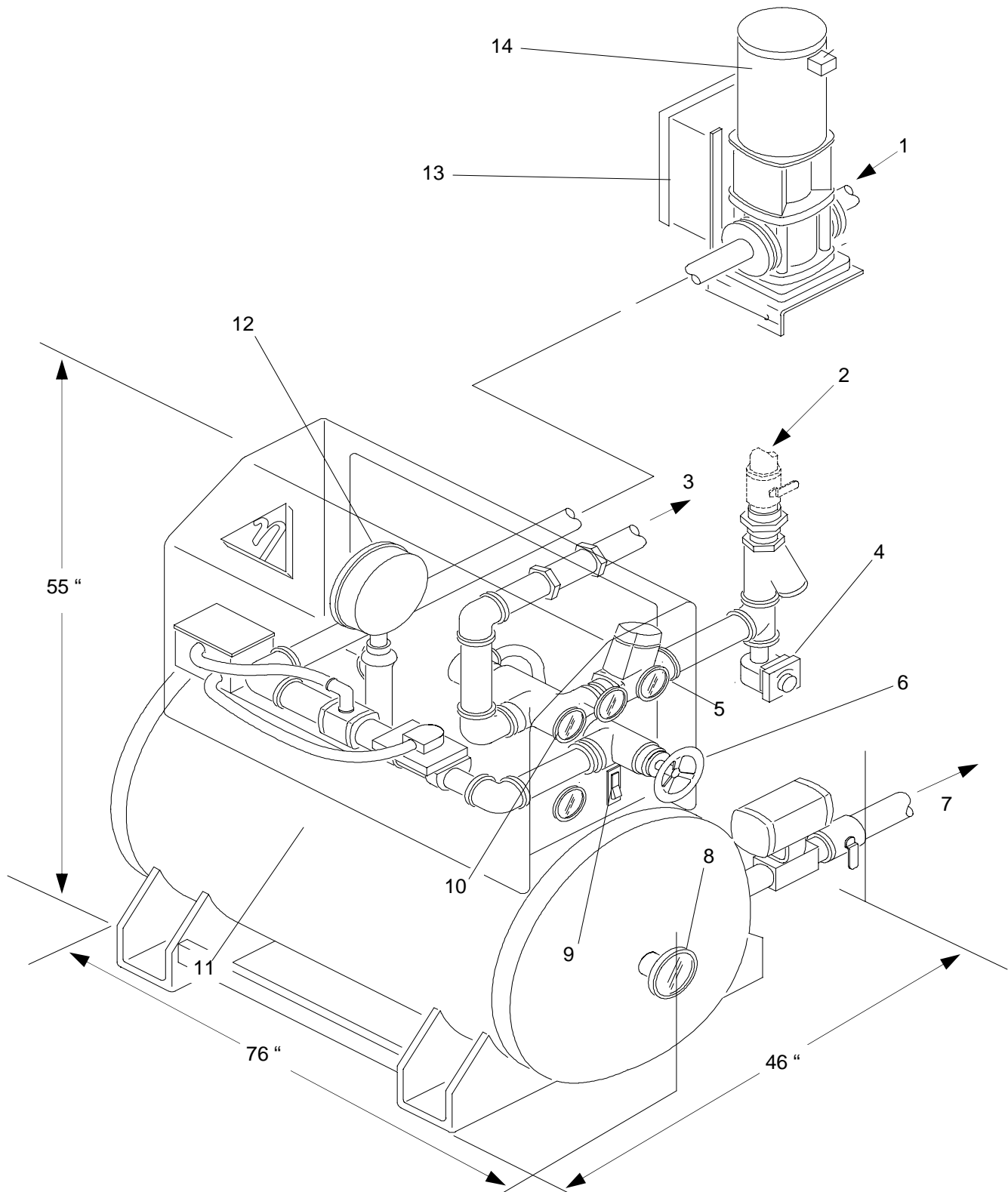

# Installation

## Compressed Air

Compressed air is required to pre charge the reserve tank (one time) and for permanent operation of the air actuated steam valve.

Refer to pages 21 & 22, item 29. Use 3/8 air line 80-120 psi. You may hard pipe the air line, but install a short hose (2-4') at the end. After charging the reserve tank, disconnect it and place it on the air actuated steam valve for permanent operation.

**Caution:** Never connect a permanent air line to the reserve tank, always disconnect after charging.

## Floor Drain

Pipe the Start-up/overflow downward to a drain using no less than 1-1/4" rigid pipe. See page 7, item 3.

During times of use, the HelioJET will discharge approximately one pint of hot water to drain each time it cycles on and off. Be sure the drain you choose can accommodate 200°F.

Never submerge the start-up/overflow pipe into a floor drain or sump. Always leave a little space between the end of the pipe and the waste water level in order to prevent siphoning.

Never route overflow piping overhead; doing so can impede start-up.

In some cases thrust may develop in the start-up/overflow line. To prevent movement, be sure all piping is firmly anchored.

**CAUTION!:** Never use a flexible hose on the start-up/overflow line. Always use hard pipe and be sure the selected drain can handle hot water. Firmly anchor overflow piping. Never plug, undersize, or restrict overflow piping in any way. Never pipe overflow anywhere near an occupied area. Be sure personnel are always safe from overflow splash.

## Safety Relief

Included in the C-60 package is a 600 psi safety relief, install it as per drawing (see pg. 21, Item 30). It should be piped downward, with a 1" line firmly anchored and extended to a safe drainage location.

## High Pressure Discharge Piping

To supply pressurized hot water to spray gun stations or other cleaning equipment in your facility, connect high pressure piping to the discharge ball valve (2") located at the rear of the pressure reserve tank (pg. 21, item 2).

Use 2" discharge pipe for the riser and main feeding the plant.

## Piping to Spray Drops

If your spray station will use 8 gallons per minute or less, use a 3/4" pipe from the main header to the cleaning location.

If your spray station will demand between 8-16 gallons per minute, use a 1" pipe from the main header to the cleaning location.

Use standard fluid hydraulic theory and always maintain a water velocity of less than 6 feet/second. Never undersize discharge piping as it will cause an unnecessary pressure drop at the point of use.

**CAUTION:** Be sure all pipe and fittings are rated for a least 600 psi and 200°F.

## Accessories

If liquid detergent or hot foam is required, injectors and foaming equipment (sold separately) can be installed at each cleaning station. Contact HelioJET Cleaning Technologies for information regarding our detergent injectors and hot foamers.



Electrical Schematic  
 C-60 Central System  
 460V 3 Phase  
 D00306-01

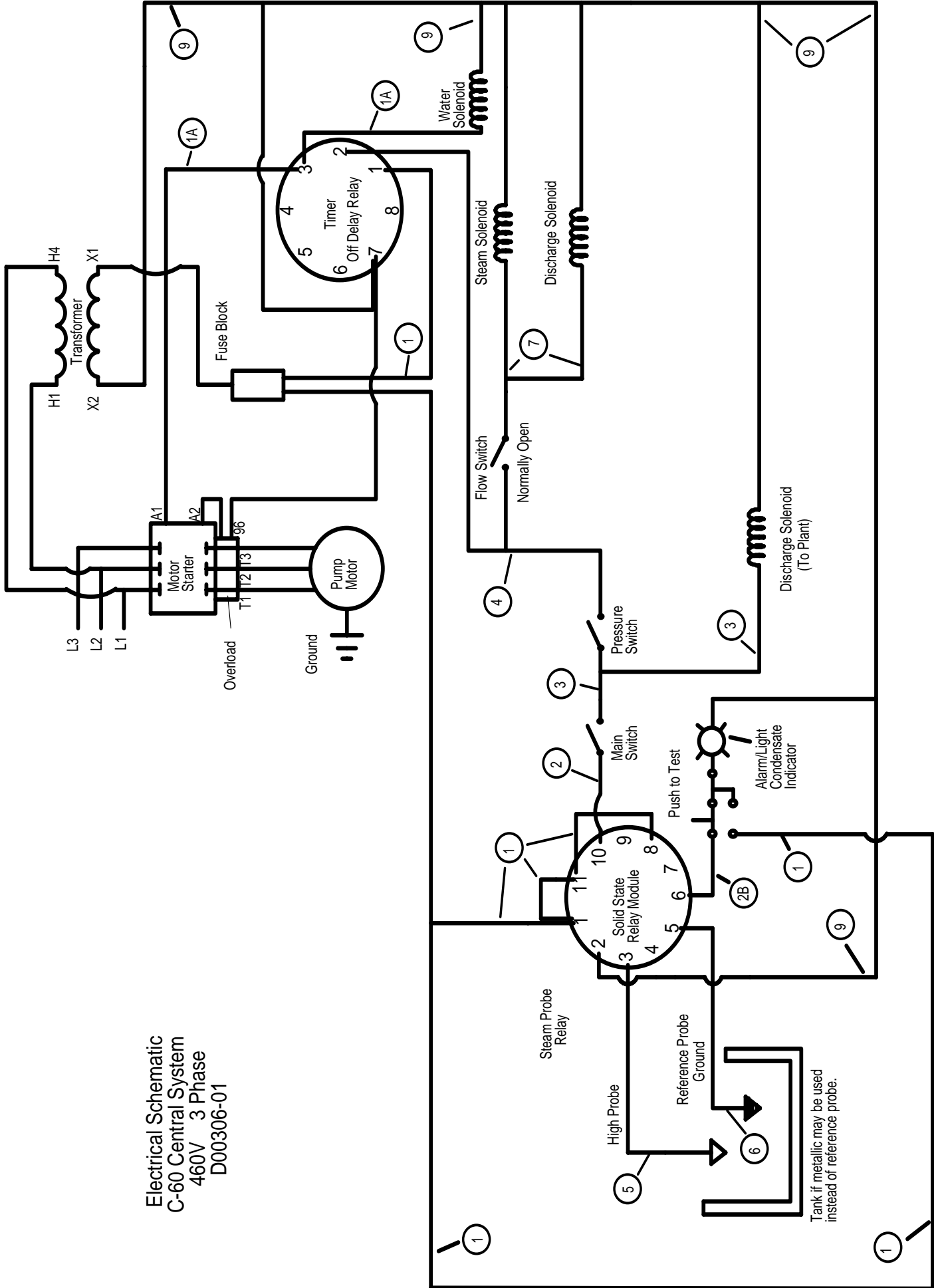

# G-7 Spray Gun Hot Foam, Sanitize

# Typical Installation

Figure 4

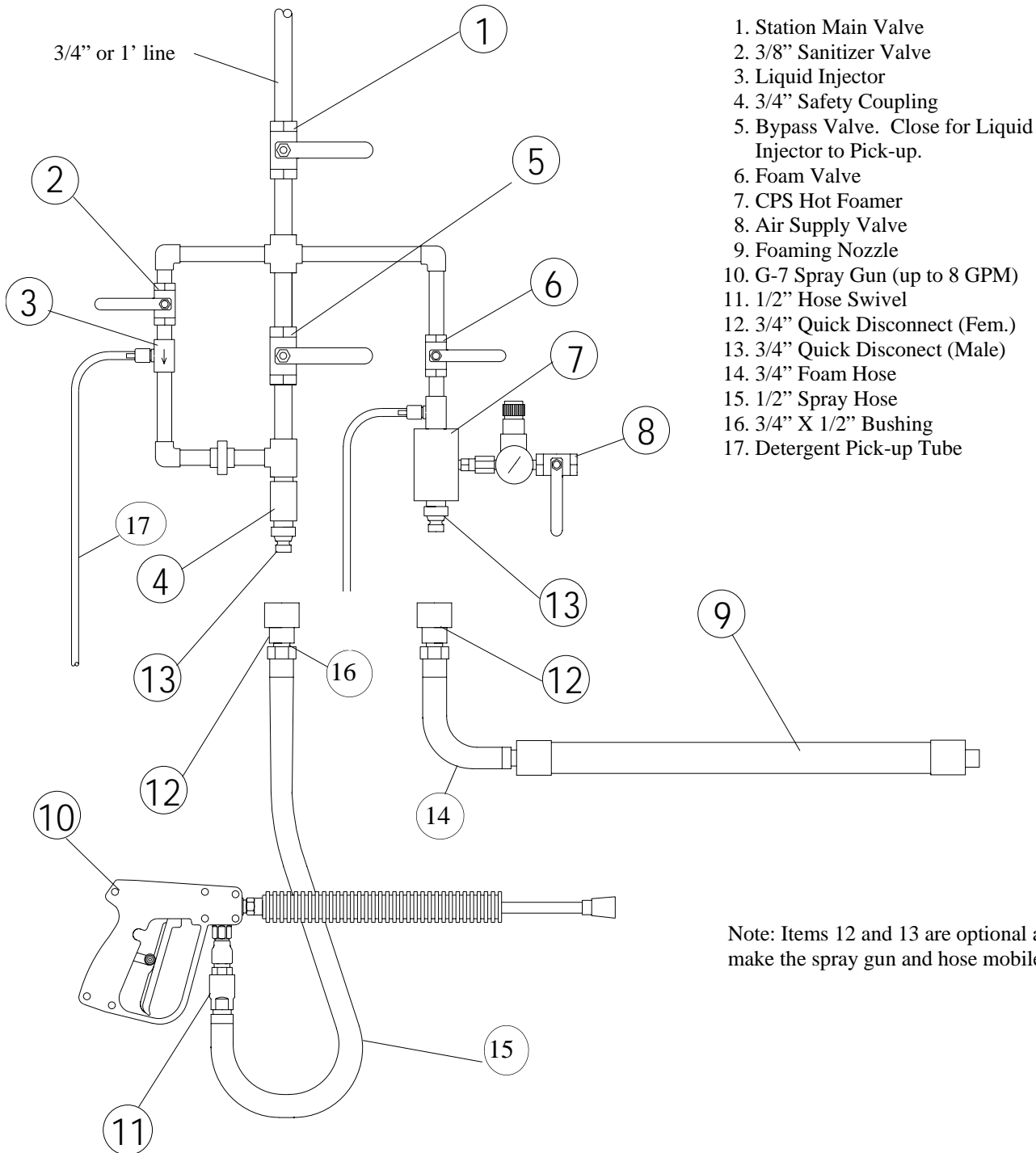

Note: Items 12 and 13 are optional and serve to make the spray gun and hose mobile.

# Start-up

## Preparing for Initial Calibration and Start-up

After the HelioJET C-60 has been installed, complete the following steps before attempting to start the system.

### Precharge Reserve Tank

Close 2" discharge ball valve. This will prevent compressed air from entering the discharge piping that feeds the cleaning stations in your plant (pg. 21, item. 2).

Connect air hose line to the pre charge air valve located at the rear of the reserve tank (pg. 21 item 27).

Charge the reserve tank with air pressure (60-100 psi).

Close pre charge air valve, remove air hose, and place it on the air control connection located on the steam supply valve (page 21, item 33). Charging the tank is a one time procedure. It should not be necessary to repeat except during times of maintenance.

### Pump Rotation

Be sure the manual steam valve is closed and the manual water supply valve is open. Turn the power switch on and off quickly. The pump shaft should turn in the direction of the arrow located on the pump housing.

### Pump Air Lock

Remove any air that may be trapped in the pump by loosening the release plug on the upper portion of the pump body housing. The pump may be off, but the manual water supply valve feeding the system must be open.

### Remove Condensate

Be sure all condensate from the steam line has been purged and that the steam trap is working properly.

### Two Adjustments

There are two adjustments on the C-60. You will make them during the initial calibration and start-up procedure in the next section. Please refer to pages 7 and 13 to familiarize yourself with the location of the **Start-up Vacuum Gauge, Handwheel Adjustment, and High-Low Pressure Switch**. After you have located these components, you may begin the calibration and start-up procedure.

Follow proper procedures as covered in the initial calibration and start-up section below.

## Initial Calibration and Start-up

Before attempting to start this system, be sure it has been installed in accordance with all previous instructions, and that the proper procedures have been followed. If you have any questions, contact the HelioJET Technical Service Department at 1-800-444-3546.

Please read all of the following steps before beginning, and be sure to follow them in proper order:

**Step 1.** Be sure the Handwheel adjustment is turned clockwise to fully bottomed position.

**Step 2.** Adjust pressure switch (upper dial) to 575 psi (see pg. 13, fig. 5).

**Step 3.** Open manually operated water and steam supply valves to system (be sure all condensate has been drained from the steam supply line).

**Step 4.** Turn the HelioJET power switch on. Water will flow to drain from the Start-up/overflow.

**Step 5.** Observe the start-up vacuum gauge, and begin turning the Handwheel counter-clockwise. At some point the gauge will suddenly read a vacuum and water will cease to discharge from the Start-up/overflow drain. Continue to turn the Handwheel rapidly in the same direction until the vacuum reading is **8 inches**. The Handwheel is now calibrated, do not continue to adjust it. Observe the discharge pressure gauge. Pressure will build in the reserve tank until the system reaches its maximum pressure. At that time one of the following two things will occur:

## Initial Calibration and Start-up Continued

**A.** The reading of 8" on the start-up vacuum gauge will go to 0 or higher, the system will continue to run while water flows to the start-up/overflow drain.

**B.** The system will build pressure in the reserve tank to 575 psi then shut down.

If A occurs, continue on to step 5. If B occurs, skip step 5 and proceed to step 6.

**Step 6.** Adjust the high-low pressure switch (upper dial) downward until the system shuts down.

**Step 7.** After system shuts down, reduce the pressure switch (upper dial setting) an additional 50 psi (page 13).

**Step 8.** Adjust pressure switch (lower dial) to obtain a 75 psi pressure differential.

**Step 9.** Open 2" discharge ball valve in order to allow pressurized hot water to fill the plant piping network. The HelioJET may cycle on and off when you do this.

Calibration is now complete and the HelioJET is ready for use. Simply begin using the spray guns or other spray devices that are supplied by the HelioJET C-60. The HelioJET will cycle on and off automatically as it is used.

### Routine Start-up and Shut Down Procedure

Steps 1-8 are for initial calibration and start-up only. Once the Handwheel and pressure switch have been adjusted, it is only necessary to follow the routine start-up and shut down procedure described below.

During times of clean-up, the HelioJET should be left on. It will cycle on and off as pressurized hot water is used for clean-up purposes.

If the system is to be turned off until the next clean-up period, follow these routine start-up and shut down procedures:

#### Routine Start-up

1. Be sure condensation has been removed from the steam supply line.
2. Turn power switch on.

#### Routine Shut Down

1. Turn power switch off.

**Note:** In the event that the air charge in the tank is lost, it will be necessary to recharge it. Before you begin it will be necessary to purge the residual water that is in the reserve tank. For instructions on this procedure, refer to page 19 under the section entitled "How to recharge the Reserve Tank". Then follow the "Initial Calibration and Startup Procedure" as outlined above. If for any reason you must perform these procedures; remember that after the water is purged from the reserve tank it will be very important to close the manually operated 2" Discharge Valve located at the rear of the reserve tank (see page 21, item 2). After the reserve tank is charged with air. And the C-60 is fully charged with water pressure, you may then open the discharge ball valve and feed your plant with pressurized hot water. If this procedure is performed out of order, the air charge will be lost into the discharge lines feeding the plant.

If the HelioJET is left unused for a long period of time (perhaps two days or more), it is suggested that the power switch be turned off and that the manual water and steam supply valves be closed as well as the discharge ball valve.

# Initial Calibration & Start-up

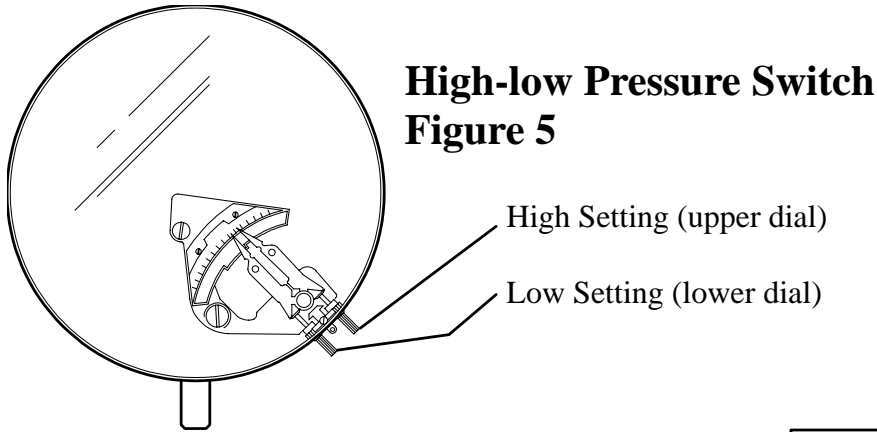

**Figure 6**

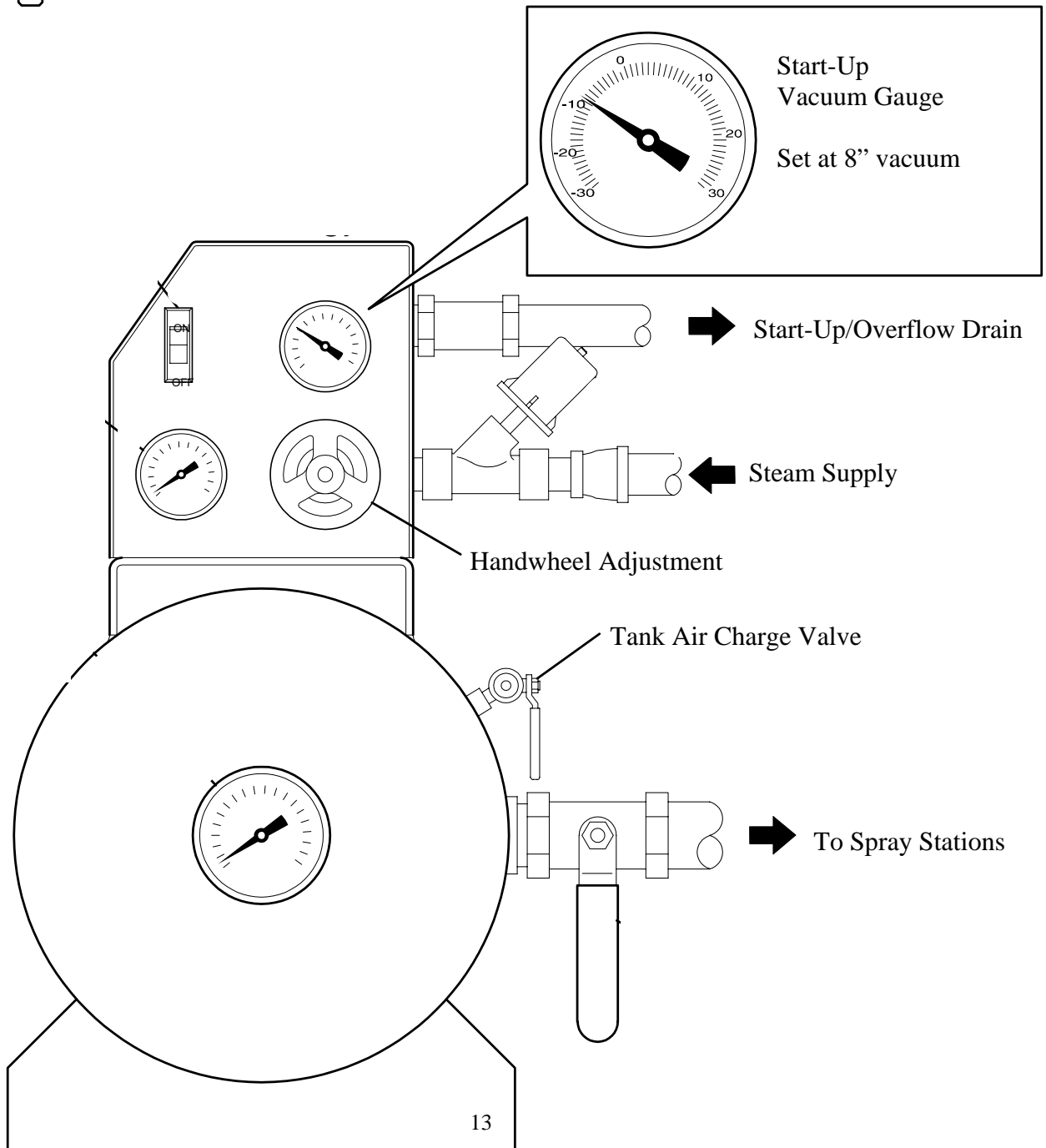

# Trouble Shooting

## CONDENSATION LIGHT

### 1- Problem

HelioJET will not start and condensate light stays lit.

### Cause and Solution

The HelioJET will not start as long as steam condensation is present in the steam supply line. The steam trap (see page 21 item 19) is designed to remove condensation from the line. When all condensation is gone the system will be aloud to start automatically.

If condensation is a re-occurring problem that delays start-up of the HelioJET, the following check list may be helpful.

A. Be sure that steam supply piping is installed correctly so that the HelioJET supplied steam trap is the lowest elevation in the piping network. Any condensate that develops should naturally flow to the steam trap.

B. Is your condensate return line piped to a riser that may prevent condensate from escaping properly? Condensate should flow down and out. If piped over head, condensate may work back into the system.

C. Steam supply line should be adequately insulated.

D. Is the Start-up/overflow drain piping routed overhead? It should be at a declining level to a drain for proper start-up.

E. Is the Start-up/overflow line at least 1-1/4" in diameter and completely free from obstructions? Never plug, restrict, or valve off the overflow.

### 2- Problem

Pressurized air discharges from the spray gun nozzle when in use. It is common for this to be mistaken for steam.

### Solution

It is likely that the overflow check valve is not maintaining a perfect seal. If it leaks it will draw air into the system that may discharge to the spray gun. Refer to page 21 and 22 item 20 for location of the Overflow Check Valve.

### 3 - Problem

The system starts and runs fine, but does not deliver the discharge temperature anticipated.

### Solution

Before start-up, the reserve tank is at ambient temperature. It takes a little time to rise to full temperature. For instance, after the first cycle, the discharge thermometer may read 140-150°F and you are expecting 180°F. Use the system and allow it to cycle on and off about 3-4 times, it should not take more than 10 minutes to come up to temperature. Keep in mind that discharge temperature may vary with water supply temperature.

#### **4 - Problem**

Spray gun does not deliver enough pressure.

#### **Solution**

- A. To insure safety, valve off, lock-out, and remove any pressure that may be in the discharge hose that supplies the spray gun.
- B. Remove nozzle at tip of spray gun, inspect for plugging or damage.
- C. Are you using well maintained and proper spray nozzles? Contact HelioJET for recommendations on nozzle sizing.
- D. Are you using a HelioJET recommended spray gun? Most spray guns available on the market are designed for low flow applications, specific to the car wash industry. These spray guns are often not appropriate for in-plant applications, as they cause considerable flow restriction which reduces pressure and impingement at the surface being cleaned. Contact HelioJET Cleaning Technologies for spray gun recommendations.
- E. Is your discharge piping undersized? See Installation section.
- F. Is it possible that your lines have developed some mineral or other type of build-up that may be creating a flow restriction? Contact HelioJET if you are unable to resolve this problem.

# Preventative Maintenance

After the HelioJET is installed and adjusted properly, it is recommended that a monthly inspection be performed to verify that the pressure switch and Handwheel settings have not been changed. If necessary, reset according to the initial calibration and start-up section of this manual.

## Flow Switch Maintenance

For location of the flow switch see page 21, item 12. The flow switch acts as a safety and timing mechanism for the air actuated steam valve. When water supply to the HelioJET is adequate, the flowing water lifts the metering disc which raises the magnet. The magnet completes the circuit allowing power to the steam valve. If the flow switch does not function properly it will affect steam valve operation. Inspect the magnet and other components to be sure they are intact.

## Flow Switch

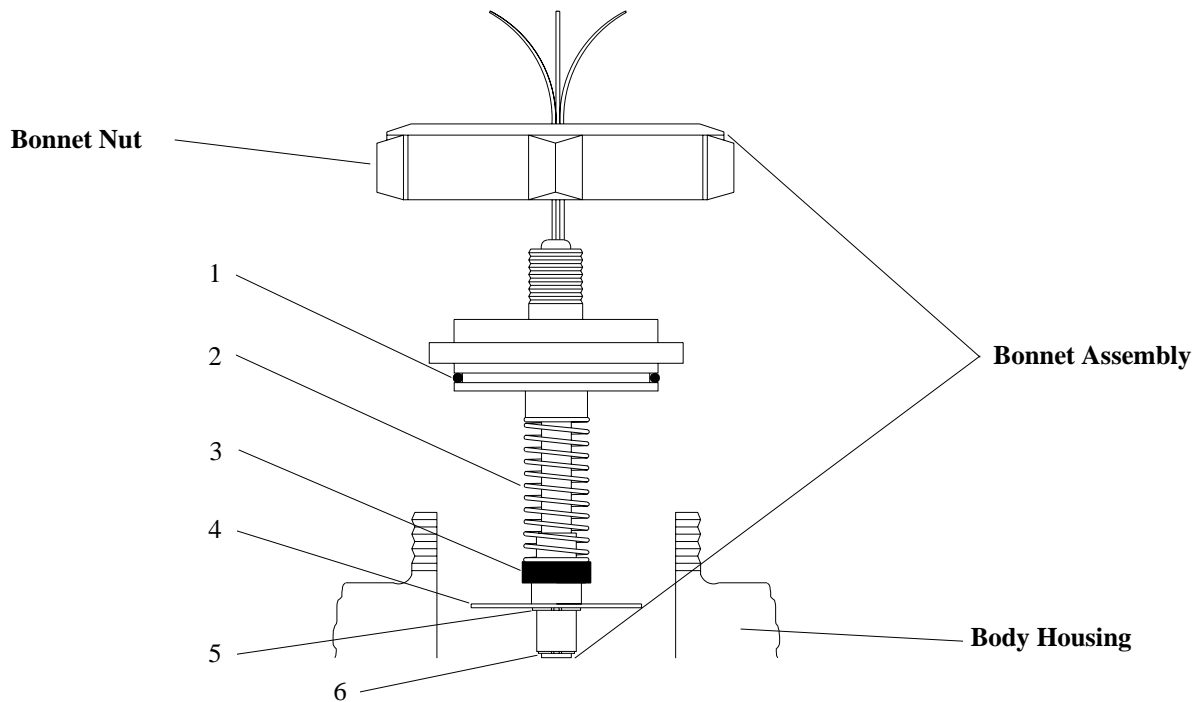

### Component Description

### Part Number

Flow Switch Complete

FS-2-15-01

Bonnet Assembly Complete

FSB-2-15-01

1. O-ring

611035

2. Spring

SPR-01

3. Magnet

MAG-01

4. Metering Disc

MD-2-15-01

5. Snap Ring

SR-01

6. Snap Ring

SR-02



**Steam Valve** (see page 21, item 31)

Check condition of steam valve seat. Does steam leak through the overflow drain, even when the C-60 System is not being used? If so, replace the steam valve seat.

**Steam Valve Solenoid**

Check condition of steam valve solenoid. Does air continuously leak from the solenoid, even when the system is not running? If so, replace the solenoid.

**Air Actuated Valve**

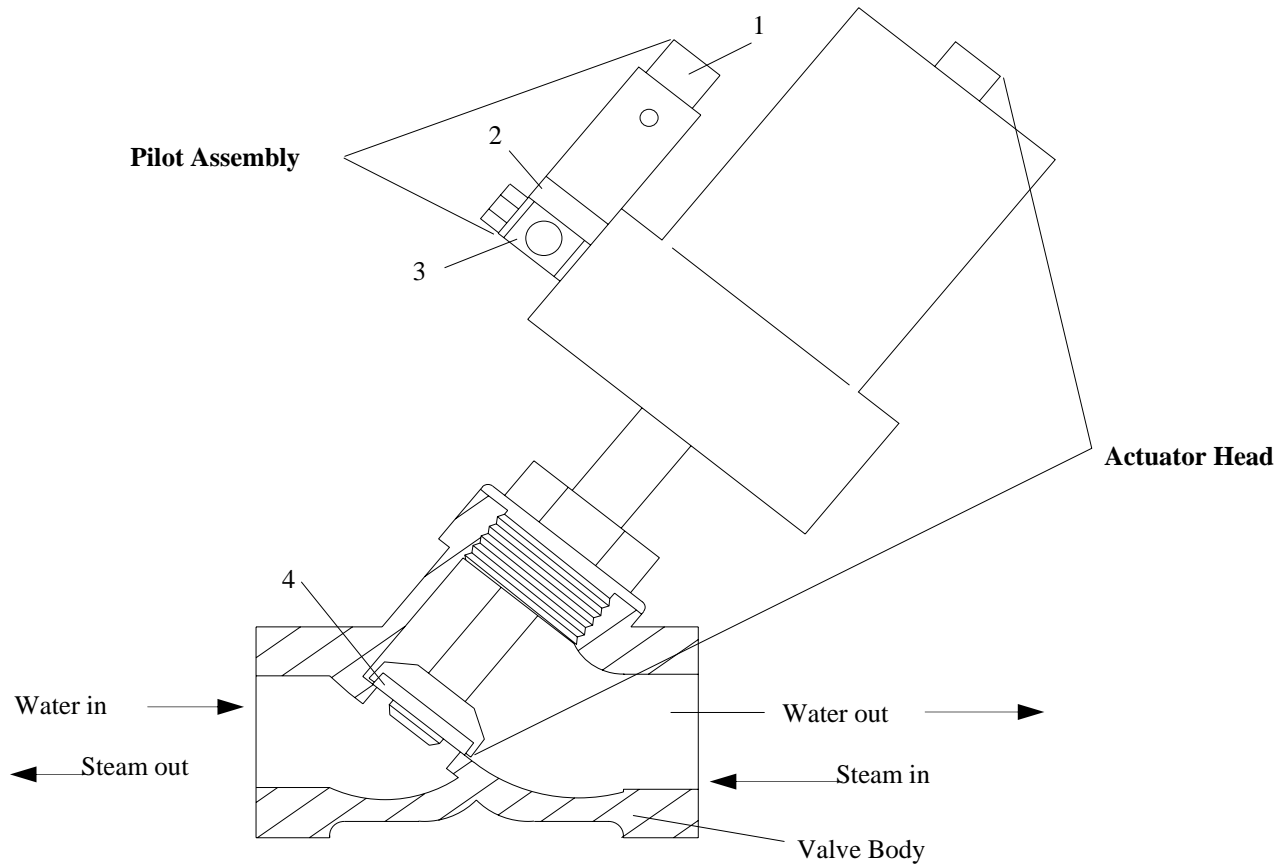

**Steam Valve Components**

**Part Number**

**Water Valve Components**

**Part Number**

Complete Valve Assembly S-AVP-2-05

Complete Valve Assembly

S-AVP-2-02

Actuator Head Assembly ACT-13

Actuator Head Assembly

ACT-10

Pilot Assembly

S-PV-01

Pilot assembly

S-PV-01

1. Conduit Plug

CP-01

1. Conduit Plug

CP-01

2. Solenoid

SOL-01

2. Solenoid

SOL-01

3. Adapter

ADA-01

3. Adapter

ADA-01

4. Valve Seat

RK-AVP-2-02

4. Valve seat

RK-AVP-2-02

### **Start-up Vacuum Reading**

Is the start-up vacuum gauge (page 21 item 7) working consistently when the HelioJET is running? If not, inspect the condition of the overflow check valve (pg. 21, item 20). If the check valve does not seat properly it will allow an excess amount of air to enter the system. This can disrupt the reading on the vacuum gauge. If the check valve proves to be in good working order, replace the gauge.

### **Noise Level**

Is the HelioJET system generating a high level of noise? Remember, normal noise level is 85 DB, but can be as high as 95. If the noise level is higher, it may indicate a reduction of air intake through the air intake nozzle and air intake check valve.

Air intake is by vacuum. As the HelioJET operates, air is drawn into the system via the air intake nozzle. The air intake serves to maintain an air charge in the pressure reserve tank and to reduce the noise level of the system during operation. A reduction in air intake is usually the cause for increased operating noise. Air intake reduction is most commonly caused by the following:

A. Sticky check valve: If the air intake check valve does not open properly, the system will not entrain air. This will result in increased noise level. To correct this, the check valve must be disassembled, cleaned, and lubricated. In some cases it may be necessary to replace or rebuild it. (see pg. 21, item 21 and 22).

B. Excessive noise can also be caused by a faulty overflow check valve. If the overflow check valve does not seat properly it can actually cause excessive air intake through the start-up/overflow line. This can result in increased noise level. If this occurs, the overflow check valve must be disassembled, cleaned, and lubricated. In some cases, the check valve will have to be replaced or rebuilt (see pg. 21, item 20).

### **Cycle Time**

Cycle time refers to the time it takes for the HelioJET to fill the pressure reserve tank once the system is activated. A normal cycle (time to fill the reserve tank) is approximately 10-20 seconds, when there is less than 10 gallons per minute being used from the reserve tank. The cycle time will increase proportionally as the demand for hot water increases. If cycle time is less than 5 seconds, inspect the following:

A. Pressure switch differential setting should always be at least 75 psi. If it is less, HelioJET cycle time will decrease proportionally.

B. The air intake nozzle and air intake check valve must be clean in order for the HelioJET to properly draw in air from the atmosphere and maintain the proper air level in the reserve tank. To inspect the air intake for free air flow, first be sure that the start-up vacuum gauge is reading an 8" vacuum when the system is running. While the HelioJET is filling the reserve tank, place your finger over the air intake nozzle. If you feel a vacuum, the air intake is working properly. For location of the air intake (see page 21, item 22).

C. If for any reason the pressure reserve tank loses its air, it will be evident as the HelioJET will cycle on and off rapidly.

To verify whether or not the reserve tank has lost its charge, first turn the C-60 power switch off. Second, close the manually operated water and steam supply valves to the system. Finally, begin draining the reserve tank by opening a spray gun or other outlet in the discharge piping. Allow the pressure in the reserve tank to drop until air begins to discharge from the spray gun or outlet. When air discharge occurs, observe the pressure gauge on the HelioJET. It should read the same pressure as the original charge (most likely 60-120 psi). If it is less, you may have lost some of the charge. If no air discharges from the gun at all, the air cushion has been depleted and it must be replenished.

### **How to Recharge the Reserve Tank**

If the reserve tank air cushion is lost, it will be necessary to replenish it. To do this, **First**, open the 2” discharge ball valve that supplies pressurized hot water to your plant. **Second**, turn the HelioJET power switch off. **Third**, close the water and steam supply valves that supply the C-60. **Fourth**, be sure there is no pressure in the reserve tank. After you have completed these four steps, begin charging the reserve tank with air pressure through the tank air charge valve. Continue to charge the tank until air begins to discharge from a spray gun or other opening in the discharge line. When this occurs the tank has been purged of water. It is important that all water is purged from the reserve tank in order to ensure proper cycle time during operation. Once the tank has been purged of water, follow the standard procedure as outlined in the section titled “**Initial Calibration and Start-up**”. After the system is operating, allow enough time for all air to be purged from the discharge lines.

**Note:** If for any reason you must perform these procedures; remember that after the water is purged from the reserve tank it will be very important to close the manually operated 2” Discharge Valve located at the rear of the reserve tank (see page 21, item 2). After the reserve tank is charged with air. And the C-60 is fully charged with water pressure, you may then open the discharge ball valve and feed your plant with pressurized hot water. If this procedure is performed out of order, the air charge will be lost into the discharge lines feeding the plant.

### **Possible Reasons for Losing the Air Charge:**

#### A. Improper Handwheel Adjustment

Improper Handwheel adjustment can cause a gradual loss of the air charge. Is there a vacuum reading of less than 4” on the vacuum gauge when the system is in operation? If so, the air cushion in the reserve tank may become depleted. A reduction in air intake as a result of low vacuum is usually accompanied by an increase in noise.

#### B. Plugged Air Intake

The air nozzle and air check valve must be clean and open in order for the HelioJET to properly draw in air from the atmosphere.

To check whether or not the air intake is clean and open for free air flow, be sure the start-up vacuum gauge reads a 8” vacuum when the system is running. While the HelioJET is running, place your finger over the air nozzle. If you feel a vacuum, the air intake is working properly. Another indication that the air intake is working properly is that there will be an increase in system noise level when you cover the air nozzle. For location of the air intake see page 21, items 21 and 22.

#### C. Open Discharge Valve

The 2” discharge ball valve to the plant should be closed when the system is not in use. If it is not closed, the tank may be drained accidentally and the air cushion lost.

#### D. Leaks

Check for leaks in the system that may have caused the loss of air to occur.

#### E. Tank Check Valve

The tank check valve may need repair or replacement if, when charging the tank, it does not develop an air cushion, or if you hear air escaping through the start-up/overflow drain (pg. 21, item 26).

For service assistance, call the HelioJET Technical Service Department at 1-800-444-3546. In order to help us serve you better, please have your equipment serial number ready for our technician.

# HelioPAC™ 60 Maintenance

# Major Components

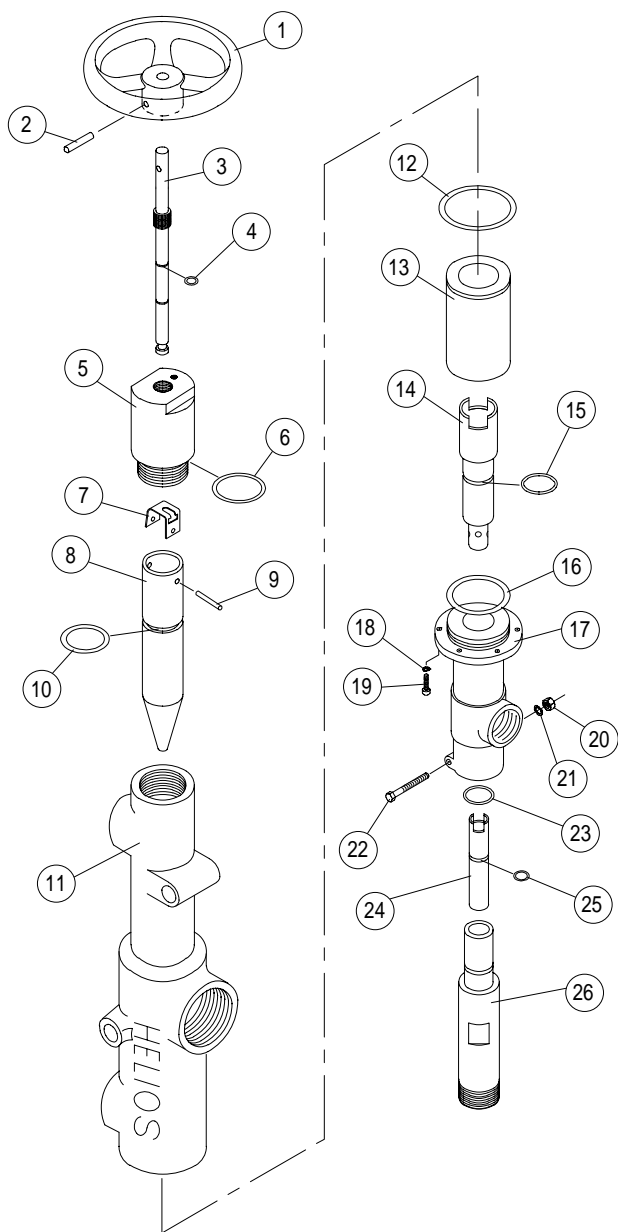

| <u>Item #</u> | <u>Description</u>               | <u>Part Number</u> |
|---------------|----------------------------------|--------------------|
| 1.            | Handwheel                        | 200189-375         |
| 2.            | Dowel Pin                        | 615008             |
| 3.            | Shaft                            | 200376             |
| 4.            | O-Ring                           | 611002             |
| 5.            | Plug                             | 200192             |
| 6.            | O-Ring                           | 611024             |
| 7.            | Bracket                          | 100122-(XXX)       |
| 8.            | Waterjet                         | 200329-(XXX)       |
| 9.            | Dowel Pin                        | 615004             |
| 10.           | O-Ring                           | 611019             |
| 11.           | Body                             | 400004             |
| 12.           | O-Ring                           | 611010             |
| 13.           | Mixing Chamber                   | 300007-114         |
| 14.           | * Amplifier                      | 200328             |
| 15.           | O-Ring                           | 611012             |
| 16.           | O-Ring                           | 611011             |
| 17.           | Manifold                         | 300038             |
| 18.           | Lockwasher (6)                   | 613001             |
| 19.           | Screw (6)                        | 612023             |
| 20.           | Hexnut                           | 614011             |
| 21.           | Lockwasher                       | 613008             |
| 22.           | Bolt                             | 612029             |
| 23.           | O-Ring                           | 611015             |
| 24.           | * Insert                         | 200238-(XXX)       |
| 25.           | O-Ring                           | 611022             |
| 26.           | Diffuser                         | 300028             |
|               | * O-Ring Kit                     | S-100027           |
|               | <i>* Recommended Spare Parts</i> |                    |

## HelioPAC™ Maintenance

After a long period of operation, wear will begin to occur at the smallest orifice diameters located in the Amplifier (#14) and Insert (#24). These two components will eventually need replacement. Indications of wear are a decrease in output pressure, and constant overflow, even after attempts have been made to adjust the handwheel and pressure switch. Blockages in these parts can also cause the similar results. To confirm that wear or blockage has actually occurred, please consult the Technical Service Department before replacing these components. Dial 1-800-444-3546.

# HelioJET™ C-60

# Major Components

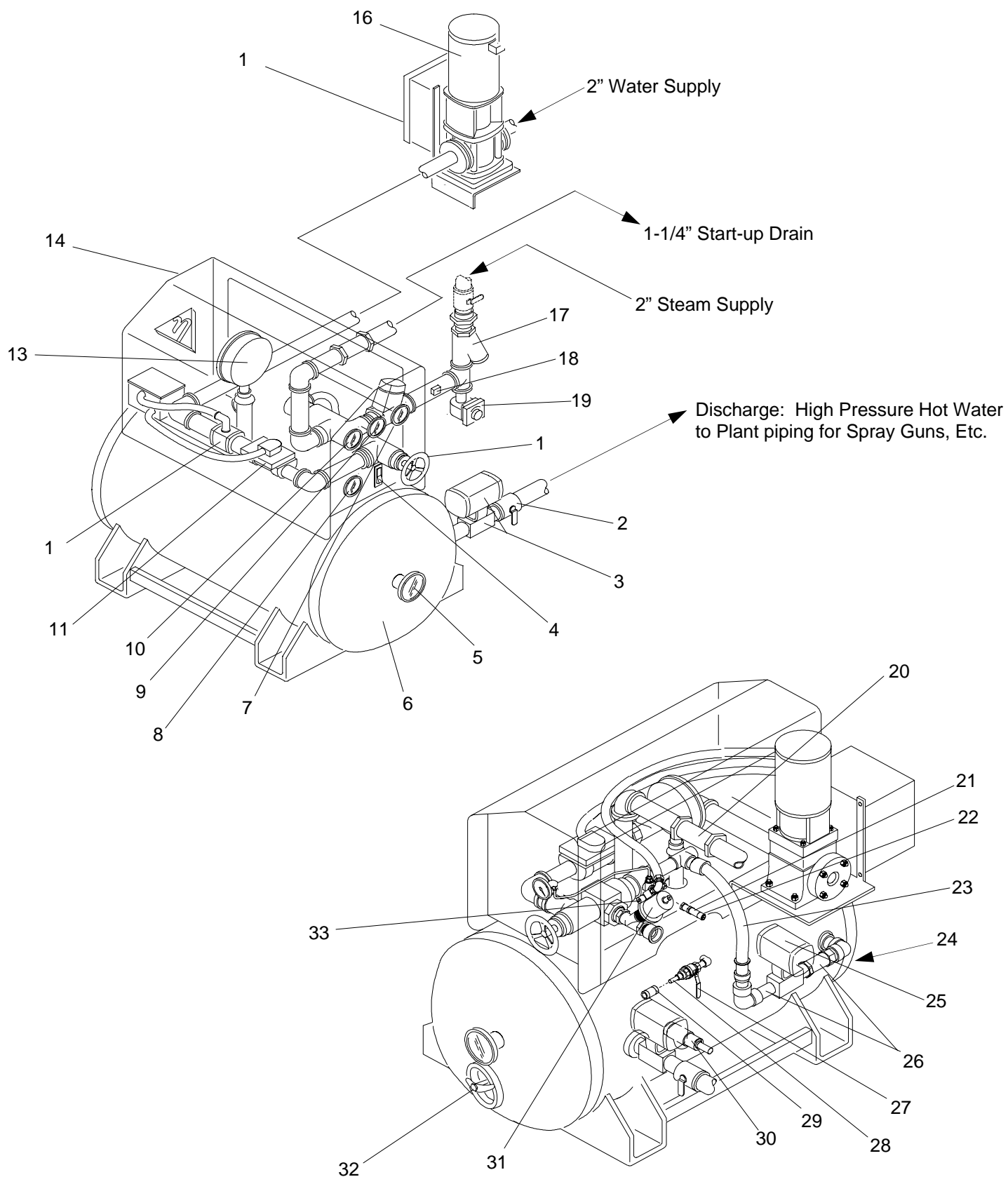

# HelioJET™ C-60

# Major Components and Spare Parts

| <u>Seq. No.</u> | <u>Component Description</u>                            | <u>Part No.</u> |
|-----------------|---|-----------------|
| 1               | HelioPAC™ 60  | PAC-60B         |
| 2               | Ball Valve (2" Manual Discharge)                        | BV-2-07         |
| 3               | Air Actuated Ball Valve (2" Discharge to Plant)         | AVB-2-07        |
| * 4             | Switch (Power)  | 629091          |
| * 5             | Thermometer (Discharge)                                 | 634007          |
| 6               | Pressure Reserve Tank (ASME Code)                       | 400047-200-COAT |
| * 7             | Gauge (Start-up Vacuum)                                 | 620037          |
| * 8             | Gauge (Discharge Pressure)                              | 620026          |
| * 9             | Gauge (Steam Supply Pressure)                           | 620025          |
| *10             | Gauge (Water Supply Pressure)                           | 620025          |
| 11              | Air Actuated Piston Valve (Water Supply)                | S-AVP-2-02      |
| 12              | Flow Switch   | FS-2-15-01      |
| *13             | Pressure Switch (600 psi)                               | PS-600-01       |
| 14              | Cover Panel   | 400057-S        |
| 15              | Electrical Enclosure                                    | 648014          |
| 16              | Booster Pump  | 643022-S        |
| 17              | Steam Strainer (2")                                     | 621012-2        |
| 18              | Steam Condensate Probe                                  | 629228          |
| 19              | Steam Trap (1/2")                                       | 637013          |
| *20             | Check Valve (Start-up/overflow)                         | CV-1-1/4-06     |
| *21             | Air Intake Check Valve                                  | CV-1/4-03       |
| *22             | Air Intake Nozzle                                       | 100054-0016     |
| *23             | Discharge Hose  | 632086-031      |
| 24              | Tank Inspection Hand Hole                               | N/A             |
| 25              | Air Actuated Ball Valve (Tank Feed)                     | AVB-1-01        |
| *26             | Tank Check Valves (2)                                   | CV-1-02         |
| 27              | Tank Air Charge Valve                                   | BV-1/4-01       |
| 28              | Quick Disconnect Nipple (Tank Air charge)               | 631001          |
| 29              | Quick Disconnect Coupler (Air Supply)                   | 631002          |
| 30              | Relief Valve (600 psi)                                  | RV-600-04       |
| 31              | Air Actuated Piston Valve (Steam Supply)                | S-AVP-2-05      |
| 32              | Tank Inspection Hand Hole                               | N/A             |
| 33              | Quick Disconnect Nipple (Control Air Supply)            | 631001          |
| *               | Air Actuated Ball Valve Repair Kit (Tank feed valve)    | RK-BV-1-01      |
| *               | Air Actuated Ball valve repair Kit (Discharge to Plant) | RK-BV-2-03      |
| *               | Steam Valve Seat  | RK-AVP-2-02     |
| *               | Steam Valve Pilot                                       | S-PV-01         |
| *               | Steam Valve Solenoid Coil                               | SOL-01          |
| *               | Flow Switch Bonnet Assembly                             | FSB-2-15-01     |
| *               | Flow Switch Magnet                                      | MAG-01          |
| *               | O-Ring Kit  | S-100027        |
| *               | <b><i>Recommended Spare Parts</i></b>                   |                 |

# Limited Warranty

Products manufactured by HelioJET Cleaning Technologies (HCT) are warranted to the original user to be free of defects in materials or workmanship for 24 months from the date of original factory shipment.

HelioJET Cleaning Technologies' liability under this warranty shall be limited to repairing or replacing at HCT's option without charge, after factory inspection of product by HCT. HCT will not be liable for any costs of removal, installation, transportation, or any other charges which may arise in connection with a warranty claim.

Valves, pumps, switches, and other components sold but not manufactured by HCT carry the above warranty for 12 months. Valve replacement seats and accessories such as hoses, spray guns, and nozzles are not warranted.

HCT will not be liable for damage or wear to products caused by abnormal operating conditions, accident, abuse, misuse, unauthorized alteration, repair, or if the product was not installed in accordance with HCT's printed installation instructions. To obtain service under this warranty, the defective product must be returned to HCT's factory in LeRoy, New York, together with proof of purchase, failure date, and supporting installation data. Any defective products to be returned to the factory must be sent freight prepaid; documentation to support the warranty claim and/or a Return Material Authorization must be included if so instructed.

**HELIOJET CLEANING TECHNOLOGIES WILL NOT BE LIABLE FOR ANY INCIDENTAL OR CONSEQUENTIAL DAMAGES, LOSSES, OR EXPENSES ARISING FROM INSTALLATION, USE OR ANY OTHER CAUSES. THERE ARE NO EXPRESS OR IMPLIED WARRANTIES, INCLUDING MERCHANTABILITY OR FITNESS FOR A PARTICULAR PURPOSE, WHICH EXTEND BEYOND THOSE WARRANTIES DESCRIBED OR REFERRED TO ABOVE.**

Some jurisdictions do not allow the exclusion or limitation of incidental or consequential damages and some jurisdictions do not allow limitations on how long implied warranties may last. Therefore, the above limitations or exclusions may not apply to you. This warranty gives you specific legal rights and you may also have other rights which vary from jurisdiction.

**HCT**  
HELIOJET CLEANING TECHNOLOGIES



HelioJET™  
Patented Equipment



He-Chem™  
Proprietary Formulations

57 North Street – Suite 120 LeRoy, NY 14482 585-768-8710